



➔ Vokèra Renewable Product Solutions

2008/2009 | *Issue 1*

ON TILE SOLAR COLLECTORS | INSET SOLAR COLLECTORS | EVACUATED TUBE COLLECTORS | PELLET BOILERS | HEAT PUMPS | TWIN COIL CYLINDERS | OPTIONS & ACCESSORIES | TRAINING





Vokèra is a licensed member of the Benchmark scheme which aims to improve the standards of installation and commissioning of domestic hot water systems in the UK.

➔ The brand of choice

Quality & Reliability

Vokèra is recognised for quality and reliability of all its products. Renewable technology is commonplace across Europe and has been part of Vokèra's parent company's, the Riello Group, portfolio for many years. Vokèra is proud to offer the Solar thermal range - 'Zenith', our wood pellet boiler - 'Neutro', our air source heat pump - 'Aria' and our twin coil cylinder - 'Aquaflow' to help you benefit from free energy in your home. All Vokèra products meet the high standards in safety, design and performance for which we are renowned.

Safety

Safety is our number one priority, Vokèra is ISO9001 approved, supports the benchmark initiative, and are members of the Heating and Hot Water Industry Council. The Vokèra Solar collectors meet the approved standard of BS EN12975 ensuring durability and performance and also have the Solar Keymark seal of approval.

Range

Our renewable product portfolio includes Solar thermal flat plate collectors 'on tile' along with 'inset' and 'evacuated tube' collectors to suit every Solar thermal application. Our wood pellet boiler, Neutro burns wood pellets that emit the same amount of CO₂ as that absorbed during the life of the tree. Our air source heat pump, Aria, utilises ambient air and extracts heat from it to provide heat for the home. All our renewable solutions help reduce CO₂ emissions and save energy.

Simplicity & Support

All Vokèra renewable products have been designed and packaged for simple application and installation. With full technical advice at every stage, Vokèra offers a seamless transition into renewable products for both the homeowner and installer. Our dedicated service team are fully trained to offer advice and guidance to installers and homeowners through all stages of an installation.





Introducing Vokèra range

Introducing renewable technology	04
Design and installation	16

Zenith Solar thermal

Zenith On tile Solar thermal collectors	06
Zenith Inset Solar thermal collectors	08
Zenith Evacuated tube Solar thermal collectors	10
Zenith Solar thermal components matrix	17
Zenith Solar thermal parts listing	18

Air source heat pump

Aria air source heat pump	12
---------------------------	----

Biomass wood pellet boiler

Neutro wood pellet boiler	14
---------------------------	----

Water cylinder

Aquaflow twin coil cylinder	15
-----------------------------	----

Service & training	19
--------------------	----

➔ Introducing Renewable Technology

About Solar thermal

Solar thermal has become one of the most cost efficient renewable technologies currently available for reducing CO₂ emissions, harnessing the Sun's natural energy to heat water.

Solar thermal collectors absorb the Sun's energy, which is absorbed by the heat transfer fluid that circulates around the collector and pipework to a twin coil cylinder that heats the domestic hot water. The water is then stored ready for supply to the taps. When the system does not heat to the required temperature the boiler steps in to make up the difference.

During the day the energy collected will steadily rise until 'solar noon' when it reaches its peak, and will steadily fall until sunset. The seasons also affect the amount of energy collected as the sun has a lower path across the skyline in winter months with shorter daylight hours.

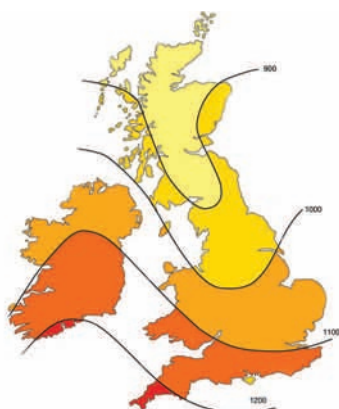

Fig 1 - Source: Solar Trade Association

Fig 1 shows the total average solar radiation falling on one m² measured in kW hours in the UK and Ireland.

Solar savings

By installing Solar thermal you can expect to save on average around 350 - 400kg of CO₂ per year.

Financial returns will depend on a number of factors including, among others, location of property, positioning of collectors on the roof, weather conditions and which fossil fuel you are replacing.

To give you a guide of the savings that can be gained, refer to the chart below (Fig 2) that provides indicative figures.

Season	%
Summer	90
Winter	30

Fig 2. Based on an ideal installation position

About air source heat pumps

Air source heat pumps utilise air to generate warmth to heat water using compression technology, providing a great source of renewable energy.

Air source heat pumps work by extracting warmth from the outside air, even when it's below 0°C. The extracted heat is then transferred to a plate-heat exchanger that heats the central heating and domestic water in a traditional way.

How efficient are air source heat pumps?

The appliance requires only a single-phase electrical supply, and depending on the ambient outside temperature – can reach a CoP (Co-efficient of Performance) of up to 3.9, i.e. 1.05kW of electrical energy to provide 4.0kW of heat output or £1 of electricity can provide £4 of heat.

The air source heat pump can be effective in temperatures ranging from -15°C to +25°C.

Can I connect an air source heat pump to Solar thermal collectors?

Solar thermal collectors can be incorporated within a heat pump system to further minimise reliance on fossil fuels.

Do I still require a traditional boiler?

A traditional – gas or oil – boiler can be used to make up any differential in temperature required, the net result is less reliance on finite fossil fuels burnt by a traditional boiler; using it instead to work simply as a back up thereby ensuring stable and continued end user home heating comfort. Air source heat pump technology is best suited to low temperature or under-floor heating systems as they require a lower flow temperature.

About wood pellet boilers

Wood pellet boilers now offer an attractive alternative to fossil fuel appliances, particularly in rural or non mains gas areas. A wood pellet boiler is low carbon technology as the CO₂ released by burning the wood pellets is absorbed by the tree during its growth, creating a carbon neutral process.

Fuel for wood pellet boilers is usually produced by using the bi product in sawmills, the sawdust is compacted into pellets that create an efficient fuel source. With the cost of traditional fuel prices set to rise, the benefits of wood pellet boilers will only increase.

Wood pellet boiler savings

Wood pellet boilers offer an attractive alternative to traditional energy producing products, particularly in rural locations where natural gas is not available.





Neutro
Biomass boiler



Aria
Air source heat pump



Zenith
Solar thermal range

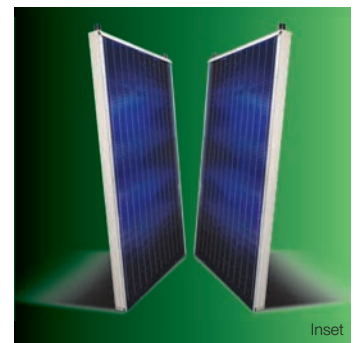

Zenith 'on tile' collectors and 'inset' collectors

Vokèra Zenith on tile flat plate collectors and inset flat plate collectors are of high build quality and are designed to use both direct sunlight and daylight to gain the maximum amount of energy throughout the whole year. Zenith on tile collectors are more suited to retro fit applications and inset collectors to new build applications or for those requiring a more discreet finish.

Zenith 'evacuated' tube collectors

Vokèra Zenith evacuated tubes are made up of 14 double sleeve evacuated glass tubes. The vacuum inside the double sleeved glass tubes provides effective thermal insulation and permits the collectors to generate heat from the sun even in bad weather and during winter months. Zenith evacuated tubes can be more efficient than flat plate collectors in colder, less sunny parts of the UK and are suitable for retro fit and new build applications.

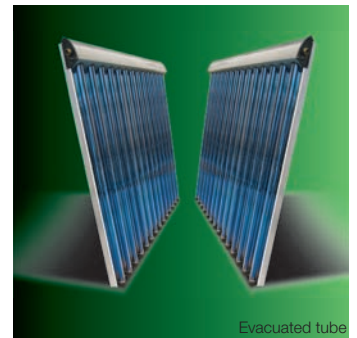

Wood pellet boilers

Vokèra Neutro wood pellet boiler provides sufficient heat for domestic central heating and can also provide domestic hot water if a vented cylinder is added to the system. Neutro burns wood pellets and is ideal in areas where natural gas is not available.

Air source heat pump

Vokèra Aria air source heat pump extracts warmth from ambient air to heat the central heating and domestic hot water in a traditional way. Sited outside a property without the requirement for any extensive installation preparation, makes the Aria an ideal renewable solution for both new build and retrofit applications.

➔ Zenith on tile Solar thermal collectors



Manufactured by Vokèra

- High build quality designed to use both direct sunlight and daylight maximising energy performance even on cloudy days.
- Ideal for retro fit applications with Solar collectors sitting on top of the roof tiles, therefore requiring minimal adaptation to the roof.
- The collectors have an aluminium body, with a single - piece copper absorber plate to create a greater reflective surface, maximising energy performance.
- Zenith Solar thermal packages include an intelligent controller for increased functionality and flexibility.
- Flat plate collectors achieve optimum performance when positioned on a south facing roof at an angle of 35° and 45°. If this position is not possible a split system could be used whereby one panel would be placed on the east facing side of the roof and another on the west.
- A highly selective finish on the copper absorber plate guarantees exceptional absorption performance.
- The collectors are ultrasonically welded together to ensure high build quality and product longevity.
- Heat transfer fluid flows through 12 individual copper pipes in the collector creating a larger surface area for the liquid, therefore increasing the level of absorption.
- As a guide 1m² of Solar collector is required per person and up to 6 collectors can be connected in a series.
- Zenith Solar thermal collector systems are pressurised which provides greater flexibility for siting of the collector and a faster reaction time to daylight and sunlight, maximising the sun's energy.
- The bottom and walls of the tray are lined with 4cm of rock wool insulation to maximise heat retention and energy efficiency.
- Low iron oxide content for high energy transmission and to minimise corrosion.
- Each collector is protected with tempered glass to withstand extreme weather conditions, such as hail stones.
- A well installed Zenith system will provide reliable, long lasting and extremely efficient service with a life expectancy of approximately 20+ years.

OPTIONS	BOILER COMPATIBILITY
AquaFlow Twin coil cylinder 250 Code 924	Mynute 12HE
	Mynute 15HE
	Mynute 20HE
	Mynute 25HE
AquaFlow Twin coil cylinder 300 Code 925	Mynute 30HE
	Mynute 35HE
	Mynute 12VHE
	Mynute 15VHE
	Mynute 20VHE



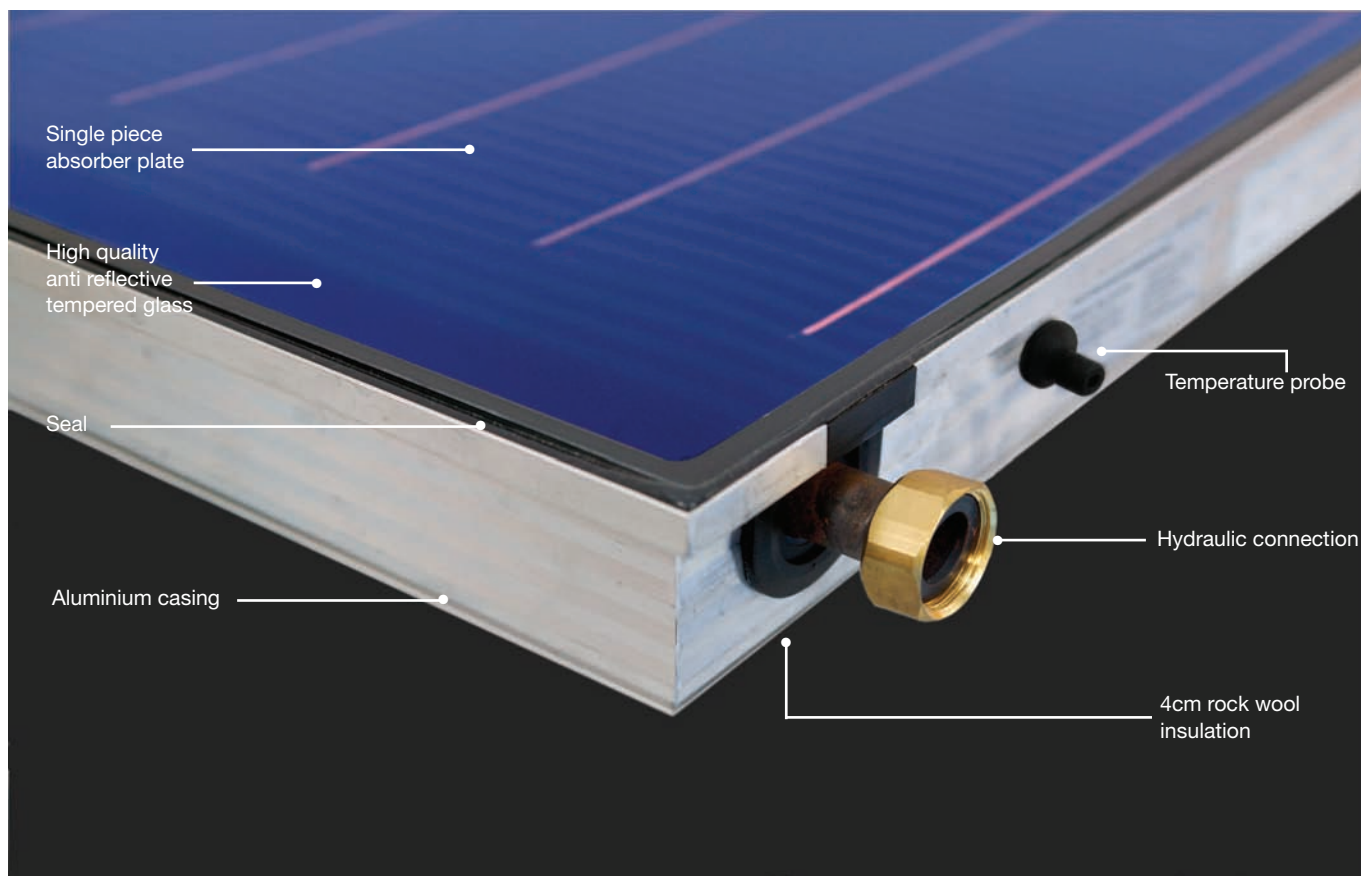

specifications

	Zenith on tile collector
Total area	2.51m ²
Exposed area	2.39m ²
Effective absorption area	2.31m ²
Connections (M - F)	1 inch
Empty weight	47 kg
Liquid content	1.65 L
Recommended flow rate per m ² of collector (per hr)	30 L
Glass type	safety glass with anti-reflective surface
Glass thickness	4 mm
Absorption (α)	95%
Emissions (β)	5%
Maximum permitted pressure	10 bar
Maximum temperature	210°C

dimensions

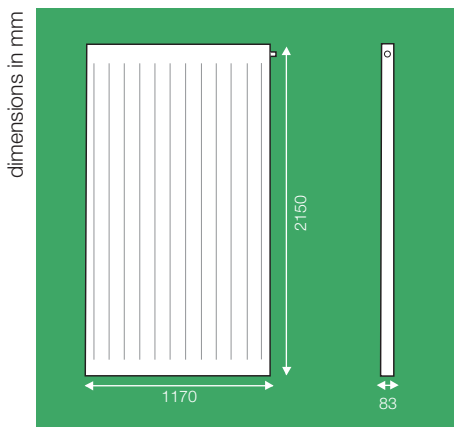

Zenith (Pitched) On Tile Collector Package Includes	Zenith (Flat) On Tile Collector Package Includes
Zenith On Tile Solar collectors (x2)	Zenith On Tile Solar collectors (x2)
Pitched roof kit	Flat roof kit
Roof fixing kit for 2 collectors	Roof fixing kit for 2 collectors
Premium controller (3 temp)	Premium controller (3 temp)
Pump station (return only)	Pump station (return only)
18L expansion vessel	18L expansion vessel
Flex & support for 18L expansion vessel	Flex & support for 18L expansion vessel
Glycol 10L (Undiluted)	Glycol 10L (Undiluted)
Manual air discharge	Manual air discharge
Insulated pipe 25m (DN15)	Insulated pipe 25m (DN15)
Fittings kit	Fittings kit
Part code	Part code
580	581



Zenith on tile collector package. Suitable in a 4 person household.

➔ Zenith inset Solar thermal collectors

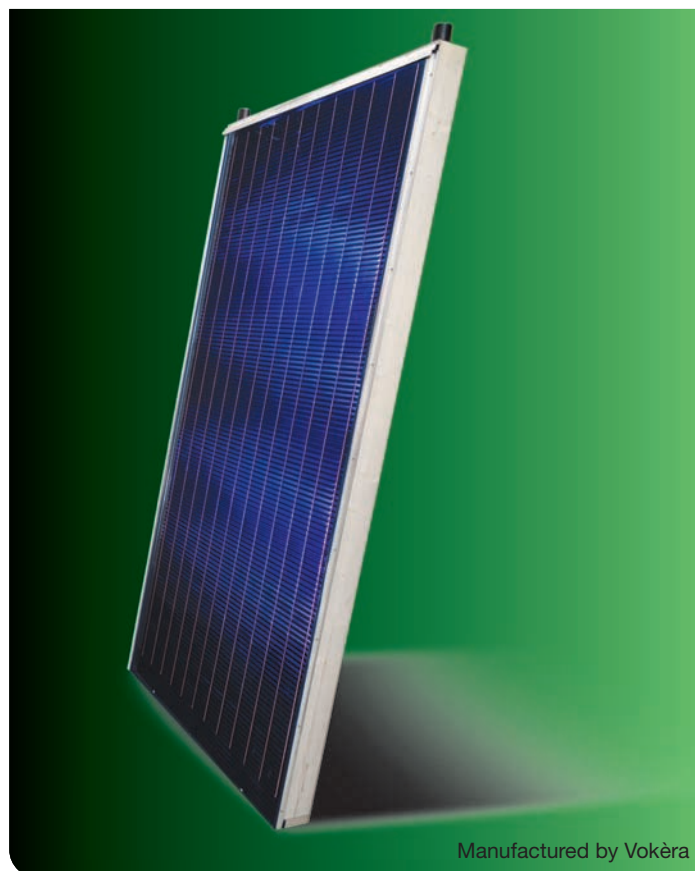

Manufactured by Vokèra

- High build quality designed to use both direct sunlight and daylight maximising energy performance even on cloudy days.
- Ideal for new build applications with Solar collectors sitting in the roof, therefore requiring less roof tiles and resulting in a neat and discreet finish.
- The collectors have an aluminium body, with a single - piece copper absorber plate to create a greater reflective surface, maximising energy performance.
- Zenith Solar thermal packages include an intelligent controller for increased functionality and flexibility.
- Flat plate collectors achieve optimum performance when positioned on a south facing roof at an angle of 35° and 45°. If this position is not possible a split system could be used whereby one panel would be placed on the east facing side of the roof and another on the west.
- A highly selective finish on the copper absorber plate guarantees exceptional absorption performance.
- Low iron oxide content for high energy transmission and to minimise corrosion.
- Heat transfer fluid flows through 12 individual copper pipes in the collector creating a larger surface area for the liquid, therefore increasing the level of absorption.
- As a guide 1m² of Solar collector is required per person and up to 6 collectors can be connected in a series.
- Zenith Solar thermal collector systems are pressurised which provides greater flexibility for siting of the collector and a faster reaction time to daylight and sunlight, maximising the sun's energy.
- The bottom and walls of the tray are lined with 4cm of rock wool insulation to maximise heat retention and energy efficiency.
- Each collector is protected with tempered glass to withstand extreme weather conditions, such as hail stones.
- A well installed Zenith system will provide reliable, long lasting and extremely efficient service with a life expectancy of approximately 20+ years.

OPTIONS	BOILER COMPATIBILITY
AquaFlow Twin coil cylinder 250 Code 924	Mynute 12HE
	Mynute 15HE
	Mynute 20HE
	Mynute 25HE
AquaFlow Twin coil cylinder 300 Code 925	Mynute 30HE
	Mynute 35HE
	Mynute 12VHE
	Mynute 15VHE
	Mynute 20VHE



Zenith
Inset Solar thermal collectors

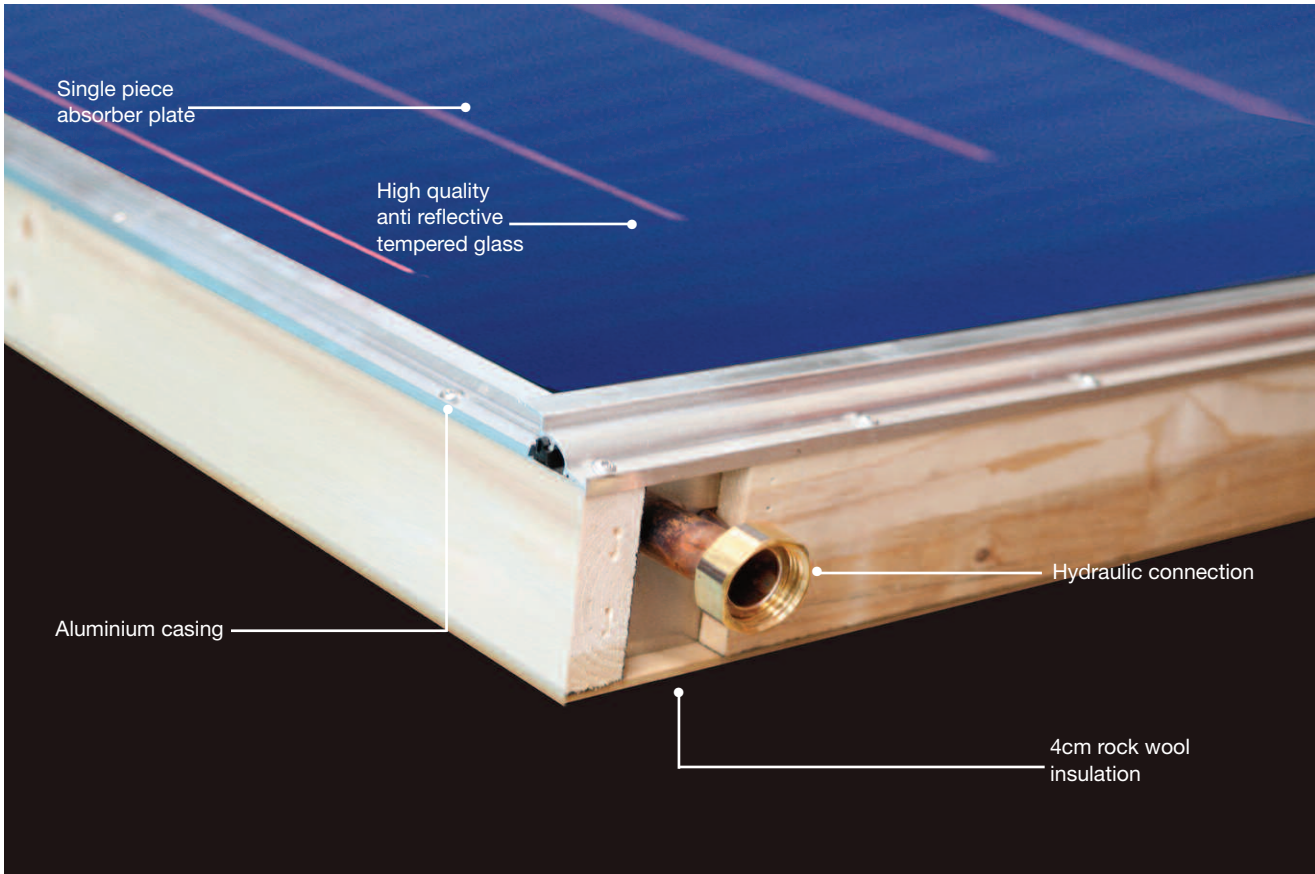

specifications

	Zenith inset collector
Total area	2.51m ²
Exposed area	2.39m ²
Effective absorption area	2.31m ²
Connections (M - F)	1 inch
Empty weight	47 kg
Liquid content	1.65 L
Recommended flow rate per m ² of collector (per hr)	30 L
Glass type	safety glass with anti-reflective surface
Glass thickness	4 mm
Absorption (α)	95%
Emissions (β)	5%
Maximum permitted pressure	10 bar
Maximum temperature	210°C

dimensions
dimensions in mm

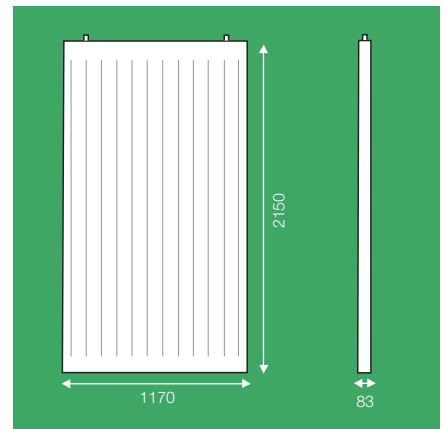

Zenith (Pitched) Inset Collector Package Includes	
Zenith Inset Solar collectors (x2)	
Roof fixing kit for two collectors	
Flashing kit for two collectors	
Premium controller (3 temp)	
Pump station (return only)	
18L expansion vessel	
Flex & support for 18L expansion vessel	
Glycol 10L (Undiluted)	
Manual air discharge	
Insulated pipe 25m (DN15)	
Fittings kit	
Part code	582

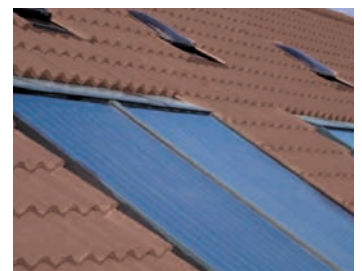

Zenith inset collector package. Suitable in a 4 person household.

➔ Zenith evacuated tube Solar thermal collectors

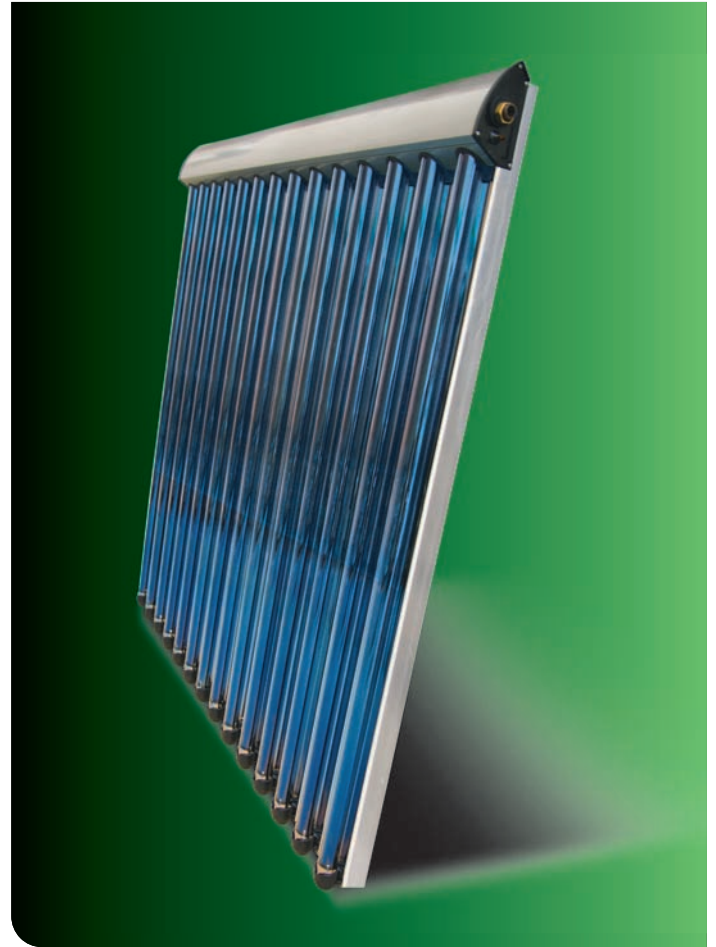

- Evacuated tube technology provides better efficiency in cooler parts of the UK due to their ability to absorb and retain Solar radiation, with the tubes working on the same principle as a vacuum flask.
- High build quality designed to use both direct sunlight and daylight maximising energy performance even on cloudy days.
- Ideal for retro fit and new build applications.
- Evacuated tube collectors are easy to install as the tubes can be removed prior to the frame being fitted onto the roof. The tubes can then be positioned within the collector frame.
- Zenith Solar thermal packages include an intelligent controller for increased functionality and flexibility.
- Evacuated tube collectors have greater application flexibility, this is due to the wider range of angles the collector can be positioned in, while maintaining effective absorption.
- Easy replacement of glass tubes without having to empty the solar heating circuit.
- As a guide 1m² of Solar collector is required per person and up to 6 collectors can be connected in a series.
- Zenith Solar thermal collector systems are pressurised which provides greater flexibility for siting of the collector and a faster reaction time to daylight and sunlight, maximising the sun's energy.
- Integrated CPC mirrors maximise absorption even in oblique light.
- A highly selective finish on the copper absorber plate within each tube guarantees exceptional absorption performance.
- 14 individual tubes in each collector.
- Long working life, with no metal parts passing through the glass tubes to cause loss of vacuum.

OPTIONS	BOILER COMPATIBILITY
AquaFlow Twin coil cylinder 250 Code 924	Mynute 12HE
	Mynute 15HE
	Mynute 20HE
	Mynute 25HE
AquaFlow Twin coil cylinder 300 Code 925	Mynute 30HE
	Mynute 35HE
	Mynute 12VHE
	Mynute 15VHE
	Mynute 20VHE



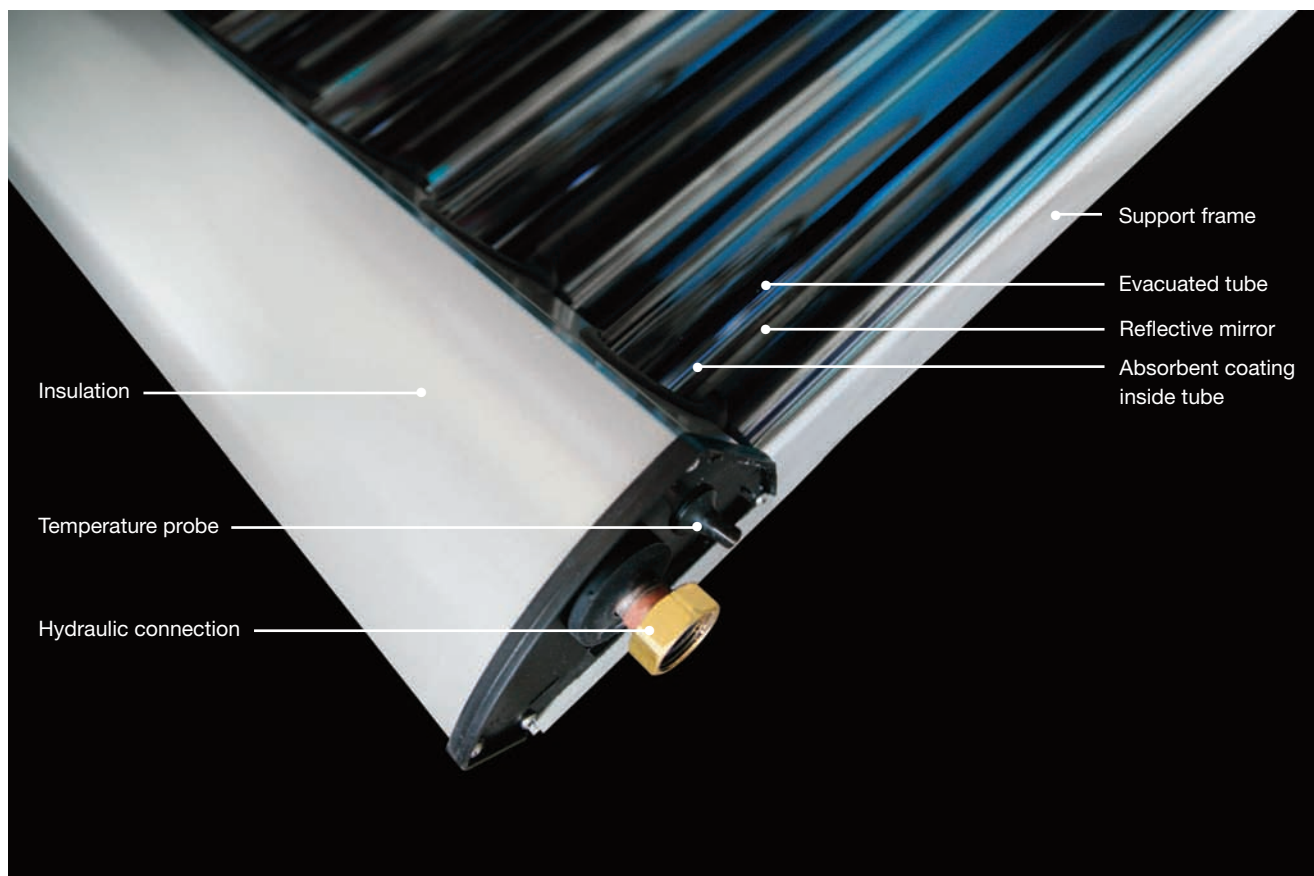

specifications

	Zenith Evacuated Tubes
Total area	2.57m ²
Exposed area	2.21m ²
Effective absorption area	2.96m ²
Connections (M - F)	3/4 inch
Empty weight	42 kg
Liquid content	2.90 L
Recommended flow rate per m ² of panel (per hr)	30 L
Absorption (α)	96%
Emissions (β)	6%
Maximum permitted pressure	10 bar
Maximum temperature	270°C

dimensions
dimensions in mm

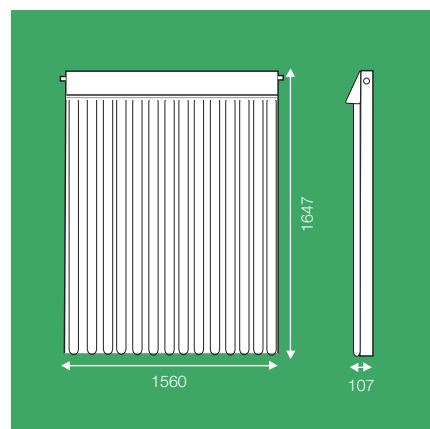

Zenith (Pitched) Evacuated Tube Collector Package Includes	Zenith (Flat) Evacuated Tube Collector Package Includes
Zenith Evacuated Tube Solar collectors (x2)	Zenith Evacuated Tube Solar collectors (x2)
Pitched roof kit	Flat roof kit
Premium controller (3 temp)	Premium controller (3 temp)
Pump station (return only)	Pump station (return only)
18L expansion vessel	18L expansion vessel
Flex & support for 18L expansion vessel	Flex & support for 18L expansion vessel
Glycol 20L (Premix)	Glycol 20L (Premix)
Manual air discharge	Manual air discharge
Insulated pipe 25m (DN15)	Insulated pipe 25m (DN15)
Fittings kit	Fittings kit
Part code 583	Part code 584

➔ Aria Air to water heat pump



- Extracts warmth from ambient air, even when outside temperature is below 0°C. The extracted warmth is then transferred to a heat exchanger that heats the central heating and domestic hot water in a traditional way.
- Co-efficient of Performance (CoP) of up to 3.9 i.e. 1.0kW of electrical energy required to generate 3.9kW of heat output (£1 of electricity can provide £4 of heat).
- Can be used for central heating and domestic hot water when connected to a water cylinder.
- The Vokèra heat pump system can incorporate Vokèra Zenith Solar thermal to further minimise reliance on fossil fuels.
- Compatible with all Vokèra boilers, which can make up any differential in heat requirement, maximising end user comfort.
- Sited outside a property without the requirement for any extensive installation preparation.
- Flexible application, suitable for both new build and retrofit applications.
- Effective in outside air temperatures ranging from -15°C to +25°C.
- Flow temperature +35°C to +50°C, making the air source heat pump ideal for underfloor heating.
- First start up 'automatic adjustment' sets the appliance, for simple installation.
- Simple to use control panel for operational adjustments and display of parameters and alarms.
- Electronically controlled variable speed helical fans that ensure silent high performance.
- Low Noise 58db.
- CFC Free Process.
- Single phase for simple installation.
- Integral heat exchanger compressor for simple installation.



features

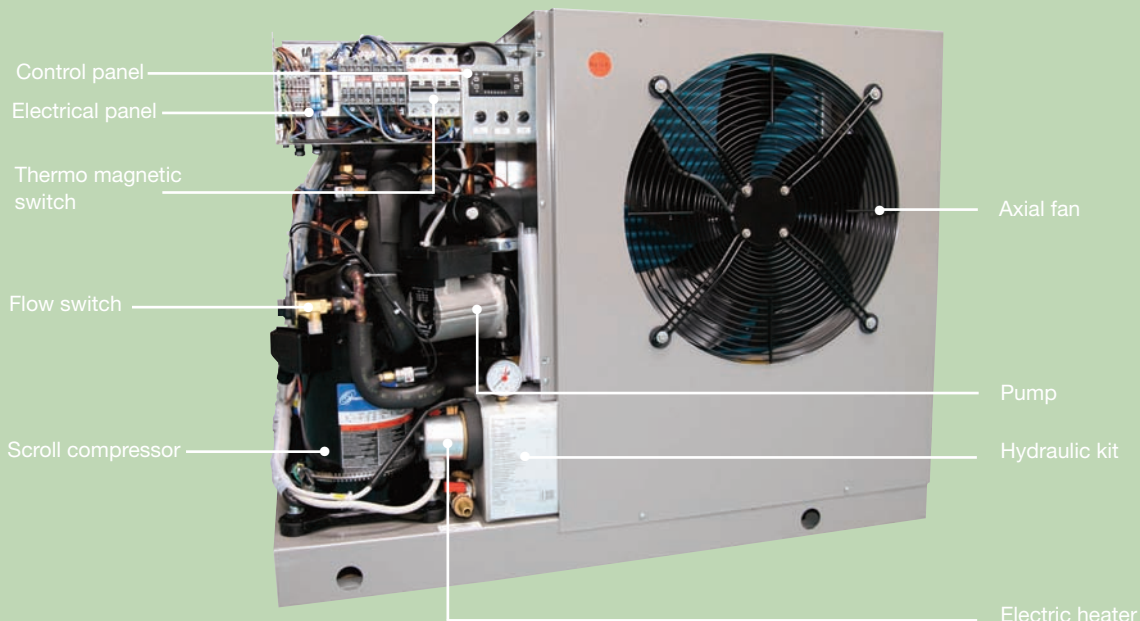

Aria
Air to water heat pump

specifications

	Aria 6.8	Aria 8.3	Aria 11
Co-efficient of Performance (1)*			
Thermal power (kW)	6.8	8.3	11
Input (kW)	1.74	2.11	2.81
COP 0/35°C	3.9	3.9	3.9
Co-efficient of Performance (2)*			
Thermal power (kW)	6.6	8.1	10.6
Input (kW)	2.14	2.68	3.5
COP 0/45°C	3	3	3
Nominal water flow (m³/h)	1	1.2	1.6
Nominal air flow (m³/h)	3.3	3.25	6.5
Noise level** (db)	58	58	62.8
Tank capacity (L)	16	16	36
Weight (kg)	110	112	164
Number of fans	1	1	2
Connections			
Inlet	3/4 inch	3/4 inch	1 inch
Reintegration	1/2 inch	1/2 inch	1/2 inch
Flow & return	BSP	BSP	BSP
Electrical			
Voltage (V/Hz)	230/50	230/50	230/50

*CoP (1) - outside air +7°C / water 30-35°C.

*CoP (2) - outside air +7°C / water 40-45°C.

**Noise level measured in free area at 1.5m from fan and 1.5m from ground

dimensions

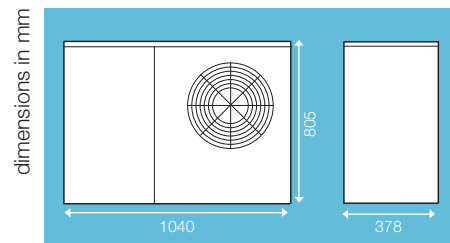

Aria 6.8kW / 8.3kW

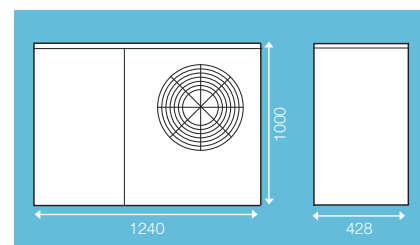

Aria 11kW

→ Neutro Wood pellet boiler

- The carbon dioxide released by burning is balanced by that absorbed by the tree during its growth, creating a 'carbon neutral' process.
- Modulating burner maintains set temperature, saving energy and upholding the optimum level of comfort.
- Up to 28 hours of continual burning without need to top up pellets.
- Adjustable combustion system to match characteristics of various pellets, ensuring maximum efficiency is obtained.
- Fume draught control pressure-stat automatically switches off the appliance if fume gas temperatures are too high, minimising wasted energy.
- Approximately 3.0kW of heat is radiated from the appliance during activity helping to create a higher level of comfort.
- Airtight chamber operation ensures all fumes are expelled via the exhaust maintaining an odourless operational appliance.
- Self cleaning ceramic glass inhibits build up of soot.
- Integral weekly programmer enabling automatic ignition and direct control over central heating timings.
- Intuitive control panel ensures end-users can easily operate and adjust the appliance.
- Automatic feed from hopper to minimise maintenance for the end-user.
- Automatic safety shutdown system prevents ignition when the hopper is empty.
- Optional two way radio control, including built in receiver, enables communication between the boiler and the external control panel, which can be sited almost anywhere in the home.
- Optional GSM module enables the end user to control the appliance via telecommunications.
- In the situation of a flue blockage and the fan fails to activate, the pressure switch safety feature disables the appliance and the boiler will not ignite.
- Can be connected to a vented cylinder to provide DHW.



Pellets



specifications

	Neutro
Output (kW)	13
Height (mm)	1015
Width (mm)	580
Depth (mm)	585
Max working water pressure (bar)	2
Boiler material	Steel
Min pellet consumption (kg/h)	1
Max pellet consumption (kg/h)	3.1
Tank capacity (kg)	28
Boiler capacity (l)	10
Weight (Dry)	230
Efficiency (%)	81.5

Options

Two way radio control
Code - Contact Sales Dept.

GSM module
Code 518



➔ AquaFlow Twin Unvented twin coil water cylinder

- Inner shell guaranteed for 25 years, made from Super-Molybdenum.
- Cylinder manufactured from high grade corrosion resistant stainless steel.
- Easy and quick to install.
- Internal secondary expansion via self generating air gap means no expansion vessel required, or fully flooded cylinder with an expansion vessel.
- Balanced cold water supply point.
- Secondary return facility on all units as standard.
- No need for 'sacrificial anode' due to excellent anti-corrosion properties of 'Super-Molybdenum'.
- No cold water feed tanks required means a dry roof space.
- Twin coil units supplied with one two port motorised valve.
- Twin coil units are supplied with one low level immersion heater factory fitted and hard wired complete with surface mounted thermostat.
- Twin coil cylinders have two thermostats, upper for boiler heating and lower for solar pre-heater.
- Cylinders are supplied with all mandatory valves and fittings.
- This cylinder can be installed and later connected to a Solar system, assisting the homeowner in spreading the cost of a Solar system.



specifications

	AquaFlow Twin 250	AquaFlow Twin 300
Unvented capacity	207 litres	239 litres
Approximate weight full	255kg	297kg
Flooded capacity	250 litres	300 litres
Approximate weight fully flooded	312kg	364kg
Height	1400mm	1600mm
Diameter	580mm	580mm

Install with a Zenith Solar thermal collector and system or regular boiler to benefit from renewable energy.

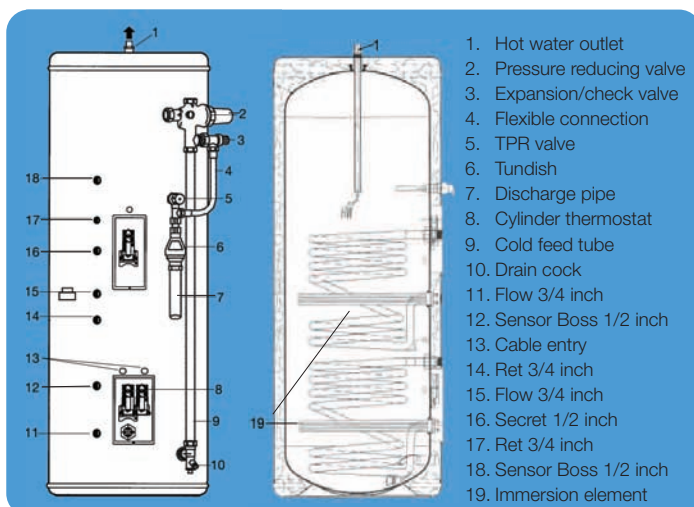

Installation

➔ Design and installation

The below diagrams show how the Vokèra renewable product portfolio can be utilised to fulfil all heating and domestic hot water requirements.

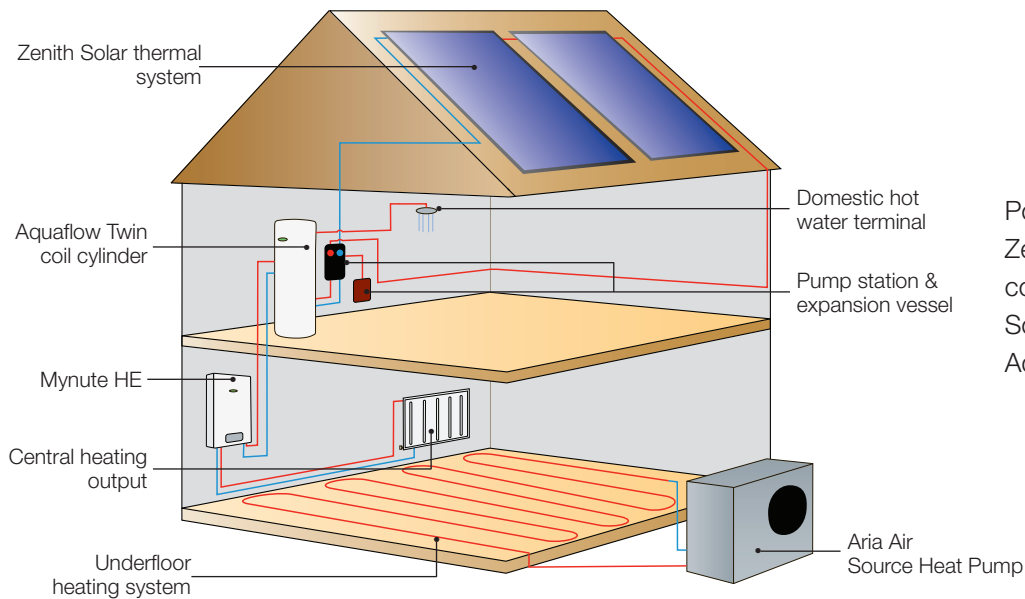

Possible installation using a Vokèra Zenith Solar thermal system combined with the Vokèra Aria Air Source Heat Pump, Mynute HE and Aquaflow Twin coil cylinder.

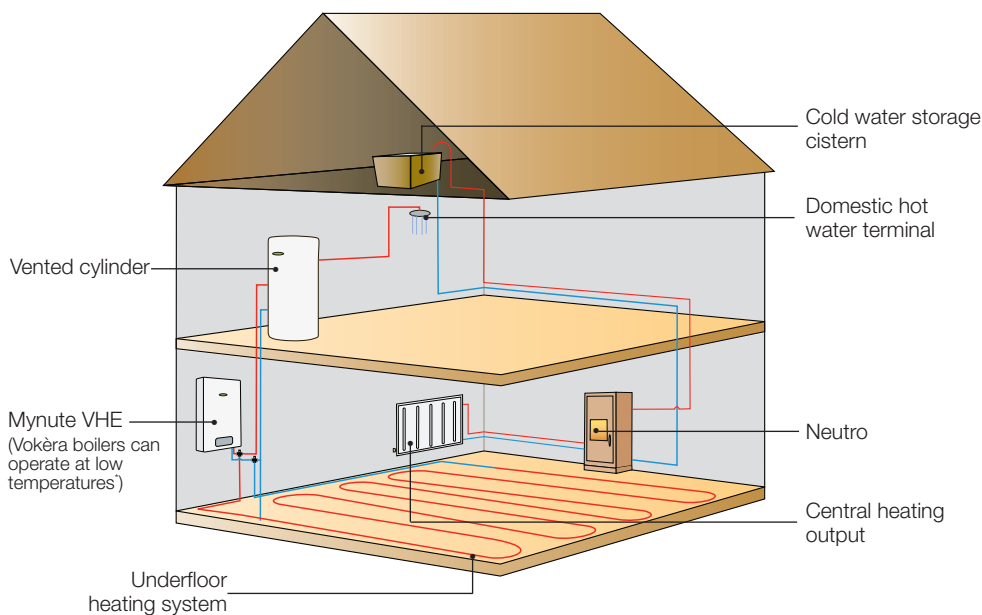

Possible installation using the Vokèra Neutro wood pellet boiler combined with the Vokèra Mynute HE and a vented cylinder.

*On selected models, please contact our technical department for details.



➔ Zenith components matrix

To order a complete Solar system order both the Primary and Secondary components in the tables below.

Primary components for Zenith Solar thermal applications

		Code	Description	1 collector	2 collectors	3 collectors	4 collectors	5 collectors	6 collectors
		On Tile collector components for pitched roof applications							
On Tile	Pitched	570	On tile collector - single	1	2	3	4	5	6
		1150849	Pitched roof fixing kit	1	1	2	2	3	3
		1150829	On tile collector kit - single	1	-	1	-	1	-
		1150859	On tile collector kit - double	-	1	1	2	2	3
		1150609	On tile jointing kit (3+ collectors)	-	-	1	1	2	2
		On Tile collector components for flat roof applications							
On Tile	Flat	570	On tile collector - single	1	2	3	4	5	6
		1150839	Flat roof fixing kit	1	1	2	2	3	3
		1150829	On tile collector kit - single	1	-	1	-	1	-
		1150859	On tile collector kit - double	-	1	1	2	2	3
		1150609	On tile jointing kit (3+ collectors)	-	-	1	1	2	2
		Inset collector components for pitched roof applications							
Inset		575	Inset collector - single	1	-	1	-	1	-
		573	Inset collector - double	-	1	1	-	-	1
		574	Inset collector - four	-	-	-	1	1	1
		20001441	Roof fixing kit	1	1	1	1	1	1
		20001442	Flashing kit - single	1	1	1	1	1	1
		20001443	Roof fixing kit - additional collector	-	1	2	3	4	5
		20001444	Flashing kit - additional collector	-	1	2	3	4	5
Evacuated tube collector components for pitched roof applications									
Evacuated Tube	Pitched	569	Evacuated tube collector - single	1	-	1	-	1	-
		571	Evacuated tube collector - double	-	1	1	2	2	3
		1151049	Pitched roof support kit - single	1	-	1	-	1	-
		1151069	Pitched roof support kit - double	-	1	1	2	2	3
		1151079	Evacuated tube jointing kit (3+ collectors)	-	-	1	1	2	2
		Evacuated tube collector components for flat roof applications							
Evacuated Tube	Flat	569	Evacuated tube collector - single	1	-	1	-	1	-
		571	Evacuated tube collector - double	-	1	1	2	2	3
		1151039	Flat roof support kit - single	1	-	1	-	1	-
		1151059	Flat roof support kit - double	-	1	1	2	2	3
		1151079	Evacuated tube jointing kit (3+ collectors)	-	-	1	1	2	2

Secondary universal components for Zenith Solar thermal applications

		Code	Description	1 collector	2 collectors	3 collectors	4 collectors	5 collectors	6 collectors
Universal components	Evacuated / Inset / On tile	1150439	Basic controller (2 temp)	1	1*	-	-	-	-
		1150449	Premium controller (3 temp)	-	1*	1	1	1	1
		1150459	Pump station 150L (return only - 1-4 collectors)	1	1	1	1*	-	-
		1150469	Pump station 300L (flow & return - 4+ collectors)	-	-	-	1*	1	1
		1150489	Expansion vessel 18L (1-3 collectors)	1	1	1*	-	-	-
		1150509	Expansion vessel 24L (3-5 collectors)	-	-	1*	1	1*	-
		1150519	Expansion vessel 35L (5-6 collectors)	-	-	-	-	1*	1
		1150499	Flex and support for expansion vessel 18L	1	1	1	1	1	-
		1150629	Manual air vent	1	1	1	1	1	1
		29450101	Insulated flexible pipe DN15 25m (1-4 collectors)	1	1	1*	1*	-	-
		29450102	Insulated flexible pipe DN20 25m (3-6 collectors)	-	-	1*	1*	1	1
		597	Hydraulic connections x12 (DN15 1 - 4 collectors)	1	1	1*	1*	-	-
		598	Hydraulic connections x12 (DN20 3 - 6 collectors)	-	-	1*	1*	1	1
		1150549	Pure Glycol 5L (On tile and inset collectors only)	1*	1*	1*	1*	1*	1*
		1150559	Pure Glycol 10L (On tile and inset collectors only)	1*	1*	1*	1*	1*	1*
		1151029	Premix Glycol 20L (Evacuated tube collectors only)	1*	1*	1*	1*	1*	1*

*Where this symbol appears you have a choice of component that will depend upon the system requirements.

**Vokèra advise that all installations should be carried out by persons having completed a full scope Solar course to ensure correct system sizing. For more details of this qualification contact our training department on 0844 391 0999, option 5.

➔ Zenith Solar thermal parts listing

Zenith Solar thermal parts listing

Code	Description
570	On tile collector - x1
569	Evacuated tube collector - x1 (14 tubes)
571	Evacuated tube collector - x2 (28 tubes)
575	Inset collector - x1
573	Inset collector - x2
574	Inset collector - x4
1150459	Pump station 150L (return only)
1150469	Pump station 300L (flow & return)
1150439	Standard controller (2 temp)
1150449	Premium controller (3 temp)
29450101	Insulated flexible pipe DN15 (25m for 1-4 collectors)
29450102	Insulated flexible pipe DN20 (25m for 3-6 collectors)
1150489	Expansion vessel 18L (1-3 collectors)
1150509	Expansion vessel 24L (3-5 collectors)
1150519	Expansion vessel 35L (5-6 collectors)
1150499	Flex and support for expansion vessel 18L
1150629	Manual air vent
597	DN15 Hydraulic connections for collectors inclusive (12 for flat plate and evacuated tube collectors)
29450103*	DN15F x F22mm Panel and air vent connection - x1 (In 597 you get 4 of these connections)
29450108*	DN15F x 1" M pump station connection - x1 (In 597 you get 2 of these connections)
29450104*	DN15F x 3/4" cylinder connection - x1 (In 597 you get 2 of these connections)
1150539*	DN15 3/4" M&F Inset/On Tile connection x1 (In 597 you get 2 of these connections)
1151019*	DN15 1" M&F Evacuated Tube connection x1 (In 597 you get 2 of these connections)
1150549	Pure Glycol 5L (On tile and Inset collectors only)
1150559	Pure Glycol 10L (On tile and Inset collectors only)
1151029	Premix Glycol 20L (Evacuated tube collectors only)
578	DN15 Couplings kit (6 connections for connecting lengths of DN15 flexible pipe)
579	DN20 Couplings kit (6 connections for connecting lengths of DN20 flexible pipe)
20001454	Solar system filling and pump trolley
Roof kits for On tile collectors	
1150829	Roof fixing kit - x1
1150859	Roof fixing kit - x2
1150849	Pitched roof kit - x1/x2
1150839	Flat roof kit - x1/x2
1150609	Jointing kit for 3+ On tile collectors
Roof kits for Evacuated tube collectors	
1151039	Flat roof support kit - x1
1151059	Flat roof support kit - x2
1151049	Pitched roof support kit - x1
1151069	Pitched roof support kit - x2
1151079	Jointing kit for 3+ Evacuated tube collectors
Roof kits for Inset collectors	
20001441	Roof fixing kit
20001443	Roof fixing kit - additional collector
20001442	Flashing kit
20001444	Flashing kit - additional collector

*Items with this symbol make up part number 597, the inclusive connections for any Zenith System

➔ Full scope solar thermal training & support

Training

Vokèra offer the Solar thermal domestic hot water course. This two day course is certificated through Logic. The course will provide a solid understanding for experienced domestic heating installers or plumbers wishing to extend their work scope into solar heating.

Vokèra recommend all installation engineers wishing to become a solar installer attend an accredited course.

The Vokèra accredited course covers:

1. Regulations and standards
2. Collector types
3. Solar heated storage types (storage cylinders)
4. Solar primary system types
5. Basic system design and integration
6. External and internal site survey, installation methods and materials
7. Filling and commissioning
8. Servicing and fault finding
9. Theory and practical examinations and assessments

To accompany this course we can also offer the Logic Certification for Unvented Water Systems G3 Certificate.

Please note that to attend the Accredited Solar Thermal Domestic Hot Water Course you should:

- Hold a G3 certificate in Unvented Hot Water Systems - If you do not have this it can be added to the Solar course.
- Hold one ODPM recognised competency in a conventional fuel i.e gas, oil or solid fuel. Or for those in the plumbing field an NVQ Level 2 or equivalent plumbing qualification.

Vokèra also offer a full range of product courses, including the Certificate in Energy Efficiency as well as tailored workshops and courses for individual needs.



View our course profiles at: www.vokera.co.uk or book now: 0844 391 0999

Active Service

We pride ourselves on providing a first class after sales service with 4 dedicated regional customer care centres in UK and Ireland, supported with 32 factory trained Vokèra field engineers along with 85 service agents, which are able to support customers nationwide. The benefits include:-

- Every engineer carries a full complement of spare parts
- Real time data field reports
- Full monthly reports on all activities to the Installer or Contractor highlighting all product and installation faults
- One point of contact to report and discuss service issues
- Full audit trail to track service calls

Our dedicated customer service team and CORGI registered engineers are available 6 days a week to support the needs of every single Vokèra installation. They respond to every call within 48 hours or less, or at a time agreed with the householder. They will make every effort to solve any technical problems over the phone, answering quickly, politely and at all times acting in the best interest of our customers.

Technical Support

Vokèra service centres and technical teams have all undergone training in Solar thermal to assist you through all stages of the planning, installation and commissioning process.

Registered address:

Vokèra Ltd

Borderlake House,
Unit 7 Riverside Industrial Estate,
London Colney,
Herts AL2 1HG

enquiries@vokera.co.uk

www.vokera.co.uk

www.vokera.ie

Sales, General Enquiries:

T 0844 391 0999

F 0844 391 0998

Vokèra Ireland

West Court, Callan,
Co Kilkenny

T 056 7755057

F 056 7755060

Vokèra Limited reserve the right to change
specification without prior notice.
Consumers statutory rights are not affected.

A Riello Group Company.

Company Reg No: 1047779

